



INTERNATIONAL APPLICATION PUBLISHED UNDER THE PATENT COOPERATION TREATY (PCT)

(51) International Patent Classification: <b>E21B 43/10</b>	<b>A1</b>	(11) International Publication Number: <b>WO 00/39432</b> (43) International Publication Date: <b>06 July 2000 (06.07.2000)</b>
(21) International Application Number: <b>PCT/NL98/00732</b>	<b>Published</b>	
(22) International Filing Date: <b>23 December 1998 (23.12.1998)</b>		
<p>(60) Parent Application or Grant                  WELL ENGINEERING PARTNERS B.V. [/]; (). BAKKER, Thomas, Walburgis [/]; (). VAN BELLE, Bart, Christian [/]; (). BAKKER, Thomas, Walburgis [/]; (). VAN BELLE, Bart, Christian [/]; (). OTTEVANGERS, S., U.; ().</p>		
<p>(54) Title: APPARATUS FOR COMPLETING A SUBTERRANEAN WELL AND METHOD OF USING SAME                  (54) Titre: APPAREIL POUR COMPLETER UN Puits SOUTERRAIN ET PROCEDE D'UTILISATION CORRESPONDANT</p>		
<p>(57) Abstract</p> <p>In completing a well bore in an underground formation, the well bore being closed off by a closing structure for blocking flow of pressurized fluid through the well bore, a substantially tubular element having a tube wall surrounding an axial bore is passed through the closing structure. The tube wall having passed the closing structure is processed along at least a portion of its axial dimension from a first condition into a second, processed condition. In the first condition, the tube wall is substantially impermeable in radial direction to pressurized fluid for precluding a flow of pressurized fluid from passing the penetrated closing structure. In the second condition the tube wall is radially permeable to pressurized fluid along at least a processed portion of its axial dimension. A tubular element to be used in such an application is described as well.</p> <p>(57) Abrégé</p> <p>Selon cette invention, lors de la complétion d'un puits de forage dans une formation souterraine, on obture le puits de forage au moyen d'une structure d'obturation afin de bloquer le flux d'un liquide sous pression s'écoulant à travers le puits, et l'on enfle à travers cette structure d'obturation un élément sensiblement tubulaire possédant une paroi tubulaire autour d'un alésage axial. On traite la paroi tubulaire enfilée dans la structure d'obturation le long d'au moins une partie de sa dimension axiale; elle passe par conséquent d'un premier état non traité à un deuxième état, traité. Dans un premier état, la paroi tubulaire est sensiblement imperméable dans le sens radial au fluide sous pression; elle empêche ainsi le flux du fluide sous pression de traverser la structure d'obturation qu'il a pénétrée. Dans un deuxième état, la paroi tubulaire est radialement perméable au fluide sous pression le long d'au moins une partie traitée de sa dimension axiale. L'invention concerne aussi un élément tubulaire utilisé dans cette application.</p>		

BEST AVAILABLE COPY

BEST AVAILABLE COPY

This area contains a large, faded grid or stamp area, likely a library or archival record. It includes various numbers and names, such as M.M.B., R.P., J.P. Vincera, G.C. Howard, J. Papaila, and E.R. Jennings. The text is mostly illegible due to fading.

BEST AVAILABLE COPY

PCT

WORLD INTELLECTUAL PROPERTY ORGANIZATION  
International Bureau



INTERNATIONAL APPLICATION PUBLISHED UNDER THE PATENT COOPERATION TREATY (PCT)

<p>(51) International Patent Classification <sup>7</sup> : E21B 43/10</p>	<p>A1</p>	<p>(11) International Publication Number: WO 00/39432</p>
		<p>(43) International Publication Date: 6 July 2000 (06.07.00)</p>
<p>(21) International Application Number: PCT/NL98/00732 (22) International Filing Date: 23 December 1998 (23.12.98) (71) Applicant (for all designated States except US): WELL ENGINEERING PARTNERS B.V. [NL/NL]; Tynaarlosestraat 68, NL-9481 AE Vries (NL). (72) Inventors; and (75) Inventors/Applicants (for US only): BAKKER, Thomas, Walburgis [NL/NL]; Tynaarlosestraat 68, NL-9481 AE Vries (NL). VAN BELLE, Bart, Christian [NL/NL]; Stromboli 18, NL-1186 CJ Amstelveen (NL). (74) Agent: OTTEVANGERS, S., U.; Vereenigde, Nieuwe Parklaan 97, NL-2587 BN The Hague (NL).</p>	<p>(81) Designated States: AL, AM, AT, AU, AZ, BA, BB, BG, BR, BY, CA, CH, CN, CU, CZ, DE, DK, EE, ES, FI, GB, GD, GE, GH, GM, HR, HU, ID, IL, IN, IS, JP, KE, KG, KP, KR, KZ, LC, LK, LR, LS, LT, LU, LV, MD, MG, MK, MN, MW, MX, NO, NZ, PL, PT, RO, RU, SD, SE, SG, SI, SK, SL, TJ, TM, TR, TT, UA, UG, US, UZ, VN, YU, ZW, ARIPO patent (GH, GM, KE, LS, MW, SD, SZ, UG, ZW), Eurasian patent (AM, AZ, BY, KG, KZ, MD, RU, TJ, TM), European patent (AT, BE, CH, CY, DE, DK, ES, FI, FR, GB, GR, IE, IT, LU, MC, NL, PT, SE), OAPI patent (BF, BJ, CF, CG, CI, CM, GA, GN, GW, ML, MR, NE, SN, TD, TG).</p> <p>Published With international search report.</p>	

(54) Title: APPARATUS FOR COMPLETING A SUBTERRANEAN WELL AND METHOD OF USING SAME

(57) Abstract

In completing a well bore in an underground formation, the well bore being closed off by a closing structure for blocking flow of pressurized fluid through the well bore, a substantially tubular element having a tube wall surrounding an axial bore is passed through the closing structure. The tube wall having passed the closing structure is processed along at least a portion of its axial dimension from a first condition into a second, processed condition. In the first condition, the tube wall is substantially impermeable in radial direction to pressurized fluid for precluding a flow of pressurized fluid from passing the penetrated closing structure. In the second condition the tube wall is radially permeable to pressurized fluid along at least a processed portion of its axial dimension. A tubular element to be used in such an application is described as well.

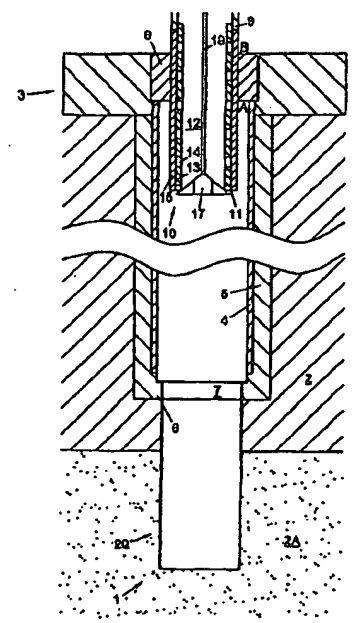

**FOR THE PURPOSES OF INFORMATION ONLY**

Codes used to identify States party to the PCT on the front pages of pamphlets publishing international applications under the PCT.

AL	Albania	ES	Spain	LS	Lesotho	SI	Slovenia
AM	Armenia	FI	Finland	LT	Lithuania	SK	Slovakia
AT	Austria	FR	France	LU	Luxembourg	SN	Senegal
AU	Australia	GA	Gabon	LV	Latvia	SZ	Swaziland
AZ	Azerbaijan	GB	United Kingdom	MC	Monaco	TD	Chad
BA	Bosnia and Herzegovina	GE	Georgia	MD	Republic of Moldova	TG	Togo
BB	Barbados	GH	Ghana	MG	Madagascar	TJ	Tajikistan
BE	Belgium	GN	Guinea	MK	The former Yugoslav Republic of Macedonia	TM	Turkmenistan
BF	Burkina Faso	GR	Greece	ML	Mali	TR	Turkey
BG	Bulgaria	HU	Hungary	MN	Mongolia	TT	Trinidad and Tobago
BJ	Benin	IE	Ireland	MR	Mauritania	UA	Ukraine
BR	Brazil	IL	Israel	MW	Malawi	UG	Uganda
BY	Belarus	IS	Iceland	MX	Mexico	US	United States of America
CA	Canada	IT	Italy	NE	Niger	UZ	Uzbekistan
CF	Central African Republic	JP	Japan	NL	Netherlands	VN	Viet Nam
CG	Congo	KE	Kenya	NO	Norway	YU	Yugoslavia
CH	Switzerland	KG	Kyrgyzstan	NZ	New Zealand	ZW	Zimbabwe
CI	Cote d'Ivoire	KP	Democratic People's Republic of Korea	PL	Poland		
CM	Cameroun	KR	Republic of Korea	PT	Portugal		
CN	China	KZ	Kazakhstan	RO	Romania		
CU	Cuba	LC	Saint Lucia	RU	Russian Federation		
CZ	Czech Republic	LJ	Liechtenstein	SD	Sudan		
DE	Germany	LK	Sri Lanka	SE	Sweden		
DK	Denmark	LR	Liberia	SG	Singapore		
EE	Estonia						

Description

5

10

15

20

25

30

35

40

45

50

55

**This Page Blank (uspto)**

5

## APPARATUS FOR COMPLETING A SUBTERRANEAN WELL AND METHOD OF USING SAME

10

## BACKGROUND OF THE INVENTION

15

The invention relates to a method for completing a well bore in an underground formation, said well bore being closed off by a closing structure for blocking flow of pressurized fluid through said well bore, comprising the step of passing a substantially tubular element having a tube wall surrounding an axial bore through said closing structure.

20

Such a method is known from practice and is carried out in the course of the completion of a well, i.e. the finalizing operations for making a well bore ready for functions such as producing oil, gas or another fluid from the formation, reservoir observation or fluid injection.

25

However, in badly consolidated or fractured formations these functions can be hampered by inflow of particles into the well bore. Such particles can originate either from the formation itself or from proppant materials used to support the completion, i.e. the section of the well bore that is to perform the above-mentioned function. Such a particle inflow does not only further destabilise the formation, but can also block the well bore or may entail the need of separating the particles from fluid produced by the well bore.

30

35

To overcome this problem, it has been proposed to support the production section using a supporting device to support the formation and any proppant used for completing the well.

40

45

From US 5 366 012, it is known to install a slotted tube as supporting device. The slotted tube is radially expanded to support the formation and/or proppant material. This is carried out when the slotted tube is located at an uncased bottom section of the borehole, and involves axially forcing a mandrel through the slotted tube to make it expand radially.

50

55

5

In practice, as part of the completion operation, after the well bore has been provided with a casing and a closing structure, such as a blow-out preventer, a production string carrying the slotted tube is passed through the closing structure.

10

5

However, since supporting devices such as slotted tubes are provided with penetrations, to be able to safely pass the supporting device through the closing structure, it is necessary to "kill" the well, by balancing the upward pressure of e.g. oil or gas in the formation with a fluid column in the well bore to avoid fluid flow from the well via the penetrations in the wall of the supporting device.

15

10

20

15

However, balancing a well is a time consuming operation which may also damage the formation and/or leave the well in an unsafe, uncontrollable condition.

25

#### SUMMARY OF THE INVENTION

20

It is an object of the invention to provide a solution which allows the completion of an uncased section of a borehole, without having to balance the well.

30

According to one aspect of the present invention, this object is achieved by carrying out a method of completing a borehole in accordance with claim 1.

35

25

This way, pressurised fluid in the well is substantially prevented from passing the penetrated closing structure, because the tube wall which is to complete the uncased section is impermeable to any pressurized fluid in the well as it penetrates and passes through the closing structure. Portions of the tube wall having been brought in position or having at least passed the closing structure are made permeable, so that fluid can be received via the initially impermeable tube wall.

40

30

45

35

According to a further aspect of the invention, a pressurized drilling fluid is axially fed through said tubular element before said processing is carried out. This

50

55

5

way, the drilling fluid can be used to power the drill and does not prematurely radially exit the tubular element through the circumferential openings.

10

According to another aspect of the present invention, the above-mentioned object is achieved by providing a tubular element in accordance with claim 10.

15

This tubular element can be passed through a closing structure for blocking a flow of pressurised fluid through a well bore, while a pressure drop over the closing structure exists without allowing fluid to the closing structure via the bore of the tubular element. In its production position, the tubular element can be made permeable to allow the fluid to be obtained from the well to pass into the production string via the tubular element.

20

Particular embodiments of the method and of the tubular element according to the invention are set forth in the dependent claims.

25

Further objects, features, advantages and details of the invention are described with reference to embodiments shown in the drawings.

30

#### BRIEF DESCRIPTION OF THE DRAWINGS

35

Fig. 1 shows schematically a cross-section of a well bore having a blow-out preventer as a closing structure being passed by a tubular element in first condition;

Fig. 1A shows an alternative embodiment of the tubular element of fig 1;

40

Fig. 2 shows the well bore of Fig. 1 with the tubular element in first condition being located in an uncased production zone;

45

Fig. 3 shows schematically a partial cross-section of a tubular element in a first condition in an uncased production zone of a bore hole;

50

55

5

Fig. 4 shows schematically a cross-section of a tubular element in a second condition in a production section of a bore hole;

10

Fig. 5 shows schematically a cross-section of another well bore having a cemented casing shoe as a closing structure being penetrated by another tubular element in a first condition; and

15

Fig. 6 shows a cross-sectional view of a wall portion of a still another tubular element.

20

#### DETAILED DESCRIPTION

20

To enhance clarity, in the drawings, the radial dimensions have been drawn on an enlarged scale relative to the axial dimensions.

15

25

Figs. 1 and 2 show a well bore 1 in an underground formation 2. The underground formation 2 has a production zone 2A which may be badly consolidated, fractured or otherwise instable. The well bore 1 is closed off by a closing structure 3 preventing pressurized fluid from flowing up through the well bore 1. The well bore 1 has a casing 4 which is sealed to the formation by a layer of cement 5.

30

35

The well bore 1 comprises a cemented casing shoe 6 through which a hole 7 has been drilled into the production zone 2A of the formation. The closing structure 3 is a conventional blow-out preventer system or a rotating preventer system. The closing structure 3 carries a packer 8 for sealing a tubing 9 passing therethrough. Such blow-out preventers are well known to those skilled in the art. In underbalanced condition, a relatively large pressure difference of 350 to 500 bar can be present between the faces A and B of the blow-out preventer.

40

45

As is shown in Fig. 1, a tubular element 10 having a tube wall section 11 surrounding an axial bore 12 is passed through an opening in the blow-out preventer 3. The tubular element 10 is in a first condition in which it is impermeable

50

55



5 to pressurized fluid in radial direction and able to  
withstand a pressure of up to at least 50 bar and preferably  
at least the pressure rating of the preventer system.

10 The tubular element 10 has a tube wall section 11  
5 which is weakened at circumferentially and axially  
distributed locations and composed of a tubular body 13  
having a plurality of openings 14 and a cover layer 15 on the  
outer circumference of the tubular body 13, covering the  
15 openings 14. The tubular element 10 is sealed off at its  
bottom end by a mandrel 17.

20 When passing the blow-out preventer 3 while in a  
first condition, the tubular element 10 behaves essentially  
like a normal tubing section passing the blow-out preventer.  
Hence, when passing the blow-out preventer, the risk of a  
15 blow-out caused by underbalance is greatly reduced and  
unintended flow of pressurized fluid past the penetrated  
closing structure is prevented. Therefore, there is no need  
25 to precisely balance the well pressure. Accordingly, the risk  
of overbalancing the well and thereby damaging the well is  
substantially reduced and, in addition, time is saved.

30 When the tubular element 10 has passed through the  
closing structure 3 it is passed coaxially through the casing  
4 while suspended from a transport tube 9 sealingly connected  
to the tubular element 10.

35 25 After the tubular element 10 has been positioned in  
an uncased production zone 20 of the well bore 1, the tube  
wall 11 is expanded along a major portion of its length,  
starting from a situation as shown in Fig. 3 to a situation  
40 as shown in Fig. 4. In the present example, this is carried  
out by axially retracting a mandrel 17 through the axial bore  
30 12 of the tubular element 10. Thus, the tubular body is  
radially expanded as the mandrel 17 is passed through. By  
45 radially expanding the tubular element to its second  
condition, additional support of the oil producing formation  
35 2A is provided by the expanded tube wall.

50

55

5

An alternative embodiment is shown in fig 1A. In this embodiment, radial expansion of the tube wall can be carried out by forcing an expander unit 17A downward through the tubular element 10. The bottom of the tubular element is closed off by a closing device, e.g. combined with a washing or drilling device 17B.

10

For suitable expansion methods, which are known as such, reference is made to US Patent 5 306 012. In particular, the mandrel 17 can be of a collapsible type, such that it can be inserted and retracted through the tubing 9 in collapsed condition. The mandrel 17 is suspended from a rod 18, which is also used to lower the mandrel and to pull the mandrel up.

15

10

20

Upon radial extension of the tubular body 13, the layer 15, which is substantially inextensible, is severed particularly at the locations of the holes 14 and becomes permeable in at least these locations. Due to the permeability, the pressure difference over the tube wall in the first condition is much lower than the pressure difference in the second condition. Oil and gas can now flow from the production zone 2A through the tubular element 10 into the tubing 9 and upwards through the tubing 9 under control of control valves above the well in the first condition. The pressure on the tube wall can e.g. be 350 to 1000 Bar higher than in the second condition.

25

30

35

Fig. 5 illustrates another, presently most preferred method of completing a well bore 101. In this case, the well bore 101 has a closing structure 103 at the top and a cemented casing shoe 106 at the bottom of the well bore 101. As in the previous example, boring the well bore 1 and providing it with a cemented casing 4 can be performed using techniques well known to those skilled in the art.

40

30

45

When the production zone 120 is to be drilled, a hole 107 is drilled through the casing shoe 106 and then the production zone 120 itself is drilled in the production formation 102A beyond the casing shoe 106. During drilling,

50

55

5

the drill string is rotated around its longitudinal axis, as indicated with arrow 125.

10

During drilling, pressurized drilling fluid is fed axially through the tubular element 110, e.g. through the axial bore 112 and exits the drill string through or near the drill bit 122. The tubular element is in the first condition and hence radially impermeable to the pressurized drilling fluid. This way, the drilling fluid does not exit the tubular element prematurely and can be used to power the drill and to wash away cuttings. The hole is drilled to total depth using the blow out preventer system on the surface to control the flow from the well.

15

20

20

After the tubular element 110 has been drilled sufficiently deep into the oil producing zone 102A and the tubular element 110 has reached the desired location in the production zone 120, the drill bit 122 is axially retracted through the bore 112 in the tubular element 110, i.e. in the direction of arrow 124.

25

25

30

30

This way, the tube wall 111 is radially expanded into its second condition. While being expanded, the tube wall 111 becomes radially permeable to pressurized fluid along the expanded portion of its length. Now, oil or gas can be produced from the production zone 102A. The expanding operation can be performed using an expander unit formed by or combined with the drill bit and a bottom hole assembly or with any other suitable expansion means.

35

25

40

30

45

35

Since in this mode of carrying out a method according to the invention, the drilling of at least a portion of the well bore is carried out using a drill string including the tubular element to be made permeable after reaching its production position, the time needed to prepare the production ready well bore is substantially reduced, because the operation of inserting the completion into the well bore is performed simultaneously with the operation of inserting the drill string into the well bore. Furthermore, because the tubular element can be expanded directly after the drilling

50

55

5 operations, compared to having to retrieve the tubular  
element and subsequently insert a supporting device, the  
10 chance of collapse of the borehole is greatly reduced and  
time is saved.

5 The tubular element 110 has a tube wall 111 provided  
with circumferentially and axially distributed openings 114.  
The openings are provided in a tubular body 113 which is  
15 covered by an outer layer 115A and an inner layer 115B of  
material. In its first condition, the tubular element 110 is  
10 impermeable to pressurized fluid and substantially  
inextensible. The layers 115A and 115B comprise a resinous  
20 material, such that upon radial expansion of the tube wall  
111 of the tubular element 110, the layers 115A and 115B are  
severed and do not cover the openings 114 anymore, such that  
15 the tube wall 111 becomes radially permeable to pressurized  
fluid. Preferably, the layers 115A and 115B comprise a  
25 material that sticks to the tubular body 113 in the second  
condition to prevent soiling of the production zone 102A and  
of produced gas, oil or other produced fluids by foreign  
20 particles originating from the layers 115A and 115B.

30 The layers 115A and 115B each substantially enhance  
torsion stiffness of the tubular element 110, in particular  
if fibres in the layers 115A and/or 115B are laid-up in a  
35 torsion-resistant diagonally wound configuration. Thus, even  
25 though a large number of openings or otherwise weakened  
locations are provided in order to be opened upon expansion,  
it is nevertheless possible to use the tubular element 110 to  
40 transfer the substantial torque of typically up to 5000 to  
25000 lbs required in a drilling operation.

30 The layers 115A and 115B comprise reinforcing fibres,  
preferably glass, carbon or other fibres embedded in a  
resinous matrix material. The fibres can be knitted, braided  
45 or wound to enhance the strength of the layer.

35 These constructional features contribute to providing  
a layer 115A or 115B that is sufficiently impermeable to  
pressurized fluid, sufficiently torsion resistant and that

50

55

5 does not disintegrate upon expansion of the tubular element 110, so that the formation of loose particles is kept to a minimum.

10 Since the layers 15 in Figs. 1-3 and 115A in Fig. 5 are located on the outside of the respective tubular bodies 13, 113, the tubular elements 10, 110 in the first condition have a particularly high resistance to external pressure. This is advantageous in situations in which the pressure on the outside of the tubular element 10, 110 is greater than 15 the pressure on the inside of the tubular element 10, 110, e.g. when the well is underbalanced relative to the pressure in the production zone 2A, 102A.

20 The layer 115B in Fig. 5 on the inside of the tube body 113 provides a particularly high resistance against 15 pressure from the inside of the tubular element 110, this occurs for instance when drilling fluid is supplied through the tubular element.

25 The layers 15, 115A and 115B can also serve to protect an additional structure interposed between the layer 20 and the tubular body 13.

30 Fig. 6 shows a build-up of layers in which an expandable screen 223 is interposed between an inner layer 215B of sealing material and an outer layer 215A of sealing material and to the outside of a tube body 213.

35 By providing that the screen is covered by a layer of sealing material, the expandable screen 223 is protected. The outer layer 215A for instance, protects the screen while the tubular element 210 is inserted into the casing. The inner 40 layer 15A can serve to protect the screen 213 from being 30 soiled or even clogged via the openings 14 by particles in the drilling fluid (mud). The reinforcing fibres in the matrix material 230 are shown as dots 232 and are indicated 45 with reference numeral 231.

50 Although the invention has been described in detail 35 with reference to a preferred embodiment, from the foregoing it will readily become apparent to those skilled in the art

5

that many and varied changes can be made without departing from the spirit and scope of the invention.

10

5 For example, the tube wall can also be brought from the first condition into the second condition without radial expansion, e.g. by rotating or telescoping movement of two tubular bodies relative to each other, such that a number of holes are closed off in the first condition and are opened by alignment in the second condition. Furthermore, the tube wall section can be weakened in other ways, e.g. by recesses of 10 which the material with decreased thickness is severed upon expansion, by barrel staves that overlap or that are adjacent in the first condition and that are interposed in the second condition. In addition, radial expansion using a mandrel can also be carried out by axially forcing the mandrel through 15 the tubular element downwardly, i.e. from top to bottom. Also, the production section can be located horizontally in the oil producing zone 2A. Such embodiments are readily available to the man skilled in the art and are within the scope of the following claims.

20

25

30

35

40

45

50

55

Claims

5

10

15

20

**This Page Blank (uspto)**

25

30

35

40

45

50

55

5

Claims

10

1. A method for completing a well bore (1; 101) in an underground formation (2, 2A; 102, 102A), said well bore (1; 101) being closed off by a closing structure (3; 103) for blocking flow of pressurized fluid through said well bore (1; 101), comprising the steps of:

15

a) passing a substantially tubular element (10; 110) having a tube wall (11; 111) surrounding an axial bore (12; 112) through said closing structure (3; 103); and

20

b) processing said tube wall (11; 111) along at least a portion of its axial dimension having passed said closing structure (3; 103) from a first condition into a second, processed condition;

25

said tube wall (11; 111) in said first condition being substantially impermeable in radial direction to pressurized fluid for preventing pressurized fluid from passing said penetrated closing structure (3; 103) and said tube wall (11; 111) in said second condition being radially permeable to pressurized fluid along at least an expanded portion of its axial dimension.

30

20

2. Method according to claim 1, wherein said processing of said tube wall (11; 111) involves expanding in at least a radial direction.

35

40

3. A method according to claim 1 or 2, wherein a first pressure difference is present over said tube wall (11; 111) in said first condition and a second pressure difference is present over said tube wall (11; 111) in said second condition, said first pressure difference being substantially larger than said second pressure difference.

45

30

4. A method according to any one of the preceding claims, wherein said well bore (1; 101) comprises a casing

50

55



5

(4; 104) and said tubular element (10; 110) is coaxially inserted within said casing (4; 104) using a transport tube (9; 109) carrying said tubular element (10; 110).

10

5 5. A method according to any one of the preceding claims, wherein said processing is carried out while said tube wall (11; 111) is located in an uncased production zone (20; 220) of said well bore (1; 101).

15

10 6. A method according to any one of the preceding claims, wherein, before said processing is carried out, a pressurised drilling fluid is axially fed through said tubular element (10; 110).

20

15 7. A method according to any one of the preceding claims, wherein, before said processing is carried out, drilling of at least a portion of said well bore (1; 101) is carried out using a drill string including said tubular element (10; 110).

25

20 8. A method according to any one of the preceding claims, wherein said closing structure (103) is provided in the form of a cemented casing shoe (106) at a bottom section of said well bore (101), further including the steps of  
35 25 drilling through said casing shoe (106) and drilling into said underground formation (102; 102A) beyond said closing structure (103) to provide an uncased production zone (220) of said well bore (101).

35

40

30 9. A method according to any one of the preceding claims, wherein during or after said step of processing said tube wall (11; 111) along at least a portion of its axial dimension, a drilling element (122) is axially retracted through said tube wall (11; 111).

45

35

50

55

5

10. A tubular element (10; 110) for lining an uncased production zone (20; 220) of a well bore (1; 101) in an underground formation (2, 2A; 102, 102A), said tubular element (10; 110) having a tube wall (11; 111) section surrounding an axial bore (12, 112) and being processable over at least a portion of its axial dimension from a first condition into a second, processed condition, said tube wall (11; 111) in said first condition being impermeable to pressurized fluid and said tube wall (11; 111) in said second condition being radially permeable in at least said processed portion to pressurized fluid.

10

5

15

10

20

11. A tubular element (10; 110) according to claim 10, wherein said processed portion in said second condition has an expanded cross sectional area surrounded by its external surface and a basic cross sectional area surrounded by its external surface in said first condition, said expanded cross sectional area being larger than said basic cross sectional area.

15

25

20

30

12. A tubular element (10; 110) according to claims 10 or 11, wherein said tube wall (11; 111) section in said first condition comprises a tubular body (13; 113) having a plurality of penetrations (14; 114) and at least one layer (15; 15A; 15B; 115; 115A; 115B) covering said penetrations (14; 114), impermeable to pressurized fluid and substantially inextensible, and wherein, in said second condition, said layer (15; 15A; 15B; 115; 115A; 115B) is severed and permeable to pressurized fluid over at least a portion of the axial dimension of said tube wall (11; 111) section.

35

25

40

30

45

13. A tubular element (10; 110) according to claim 12, in which said layer (15; 15A; 15B; 115; 115A; 115B) comprises a resinous material.

35

50

55

5

14. A tubular element (10; 110) according to claim 12 or 13, in which said layer (15; 15A; 15B; 115; 115A; 115B) comprises fibres (231).

10

5 15. A tubular element (10; 110) according to claim 14, in which said fibres (231) form a knitted, braided or wound structure.

15

10 16. A tubular element (10; 110) according to any one of the claims 12-15, in which said layer (15; 15A; 15B; 115; 115A; 115B) is a composite structure including fibres (231) embedded in a matrix material (230).

20

15 17. A tubular element (10; 110) according to any one of the claims 10-16, in which said tube wall (11; 111) in said first condition comprises a tubular body having a plurality of penetrations (14; 114) and sealing material sealing off said penetrations (14; 114), said sealing material being located at least on the outside of said tubular body.

25

20

30 18. A tubular element (10; 110) according to any one of the claims 10-17, in which said tube wall (11; 111) in said first condition comprises a tubular body having a plurality of penetrations (14; 114) and sealing material sealing off said penetrations (14; 114), said sealing material being located at least on the inside of said tubular body.

30

35

25

40 19. A tubular element (10; 110) according to claims 17 and 18, in which, in said first condition, an additional structure is interposed between an inner layer (215B) of sealing material and an outer layer (215A) of sealing material.

40

30

45

35 20. A tubular element (10; 110) according to claim 19, in which said additional structure is an expandable screen

50

55

5

(233), protected by said layers (215A, 215B) of sealing material in said first condition.

10

21. A tubular element (10; 110) according to any one of the claims 12-20, in which at least in said second condition said layer (15; 15A; 15B; 115; 115A; 115B) or said sealing material at least substantially adheres to said tubular body (13; 113).

15

20

25

30

35

40

45

50

55

1/7

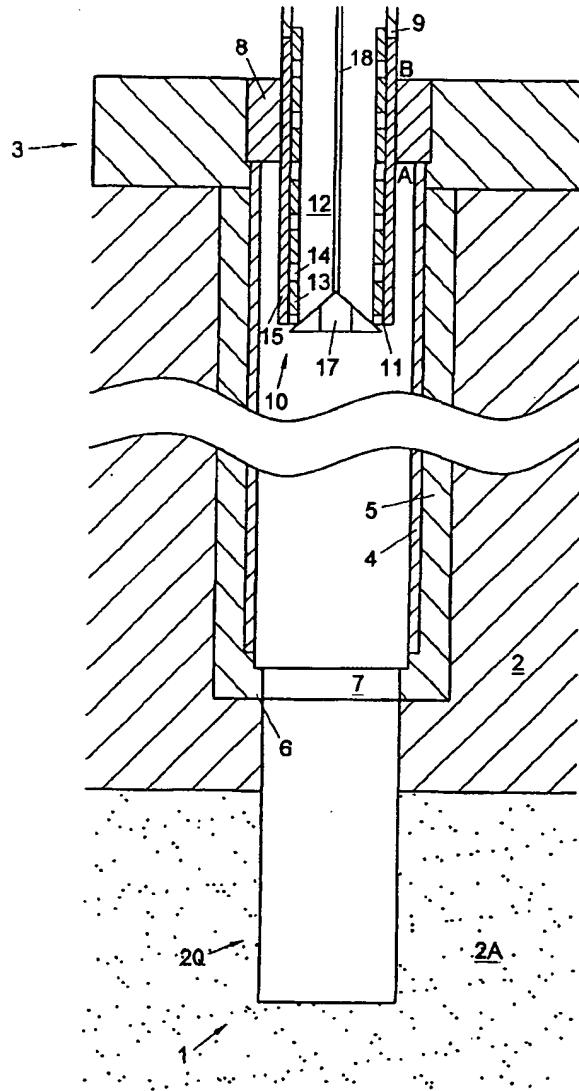

Fig. 1

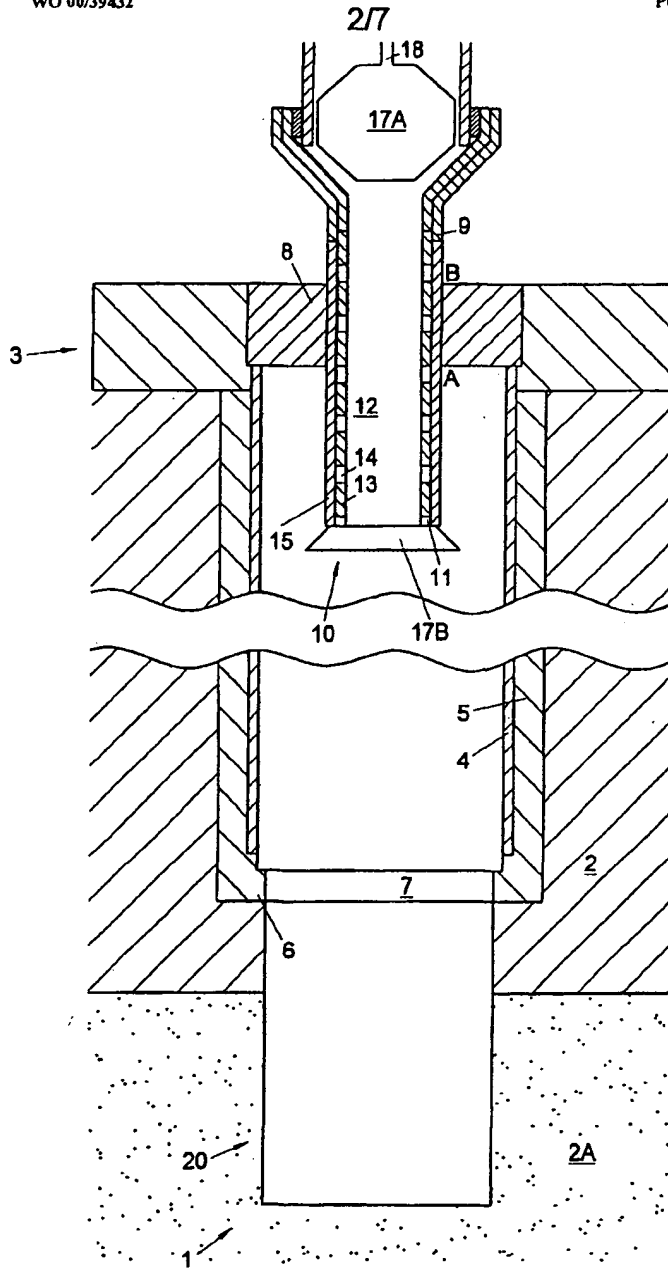

Fig. 1A

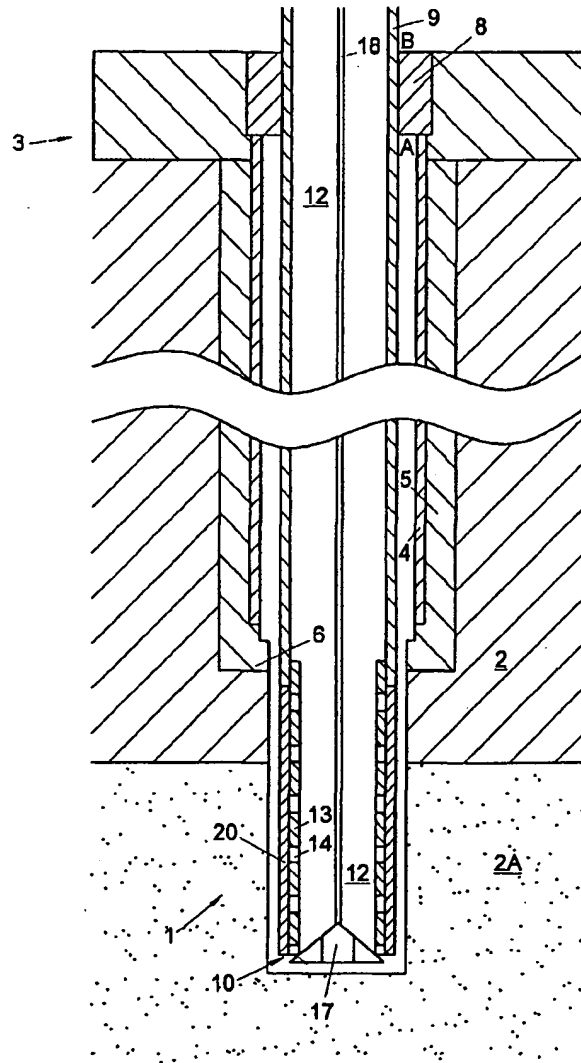

Fig. 2

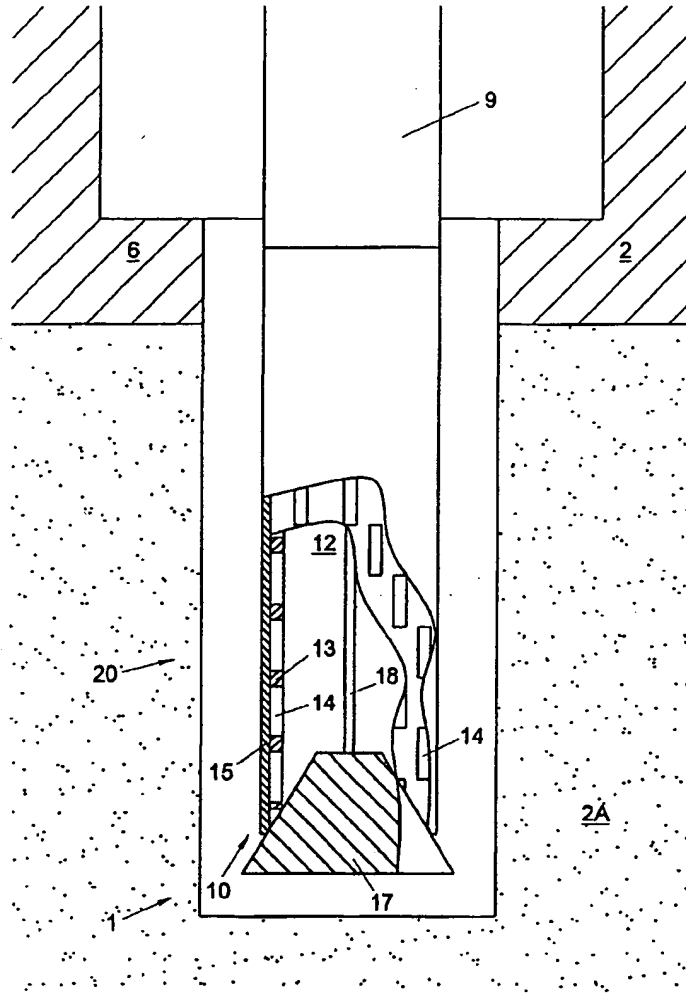

Fig. 3



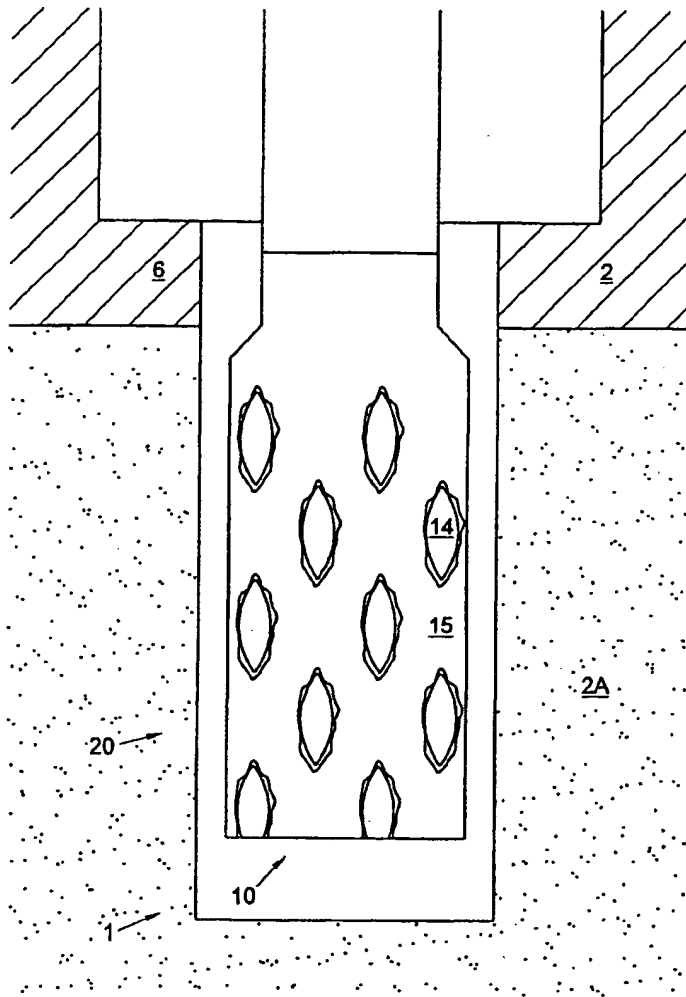

Fig. 4

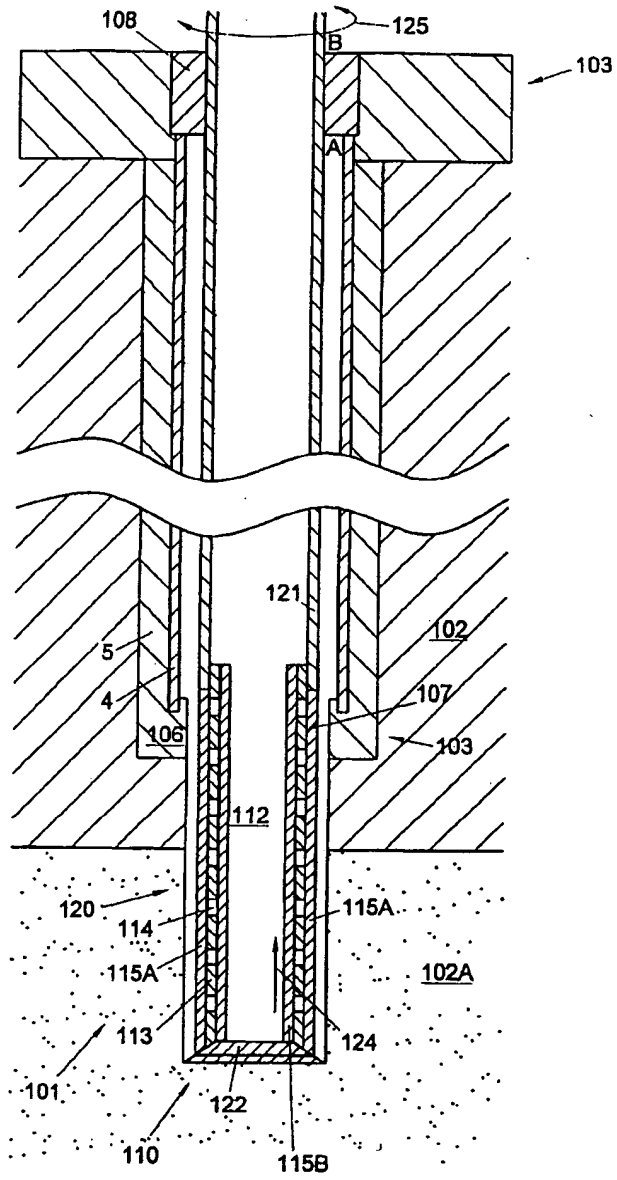

Fig. 5

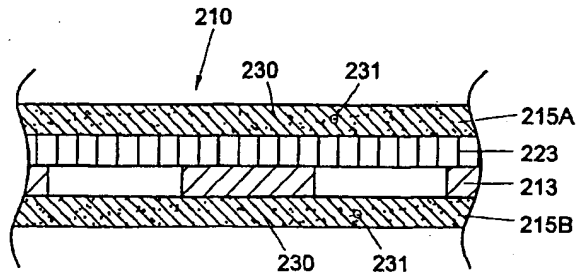

Fig. 6

INTERNATIONAL SEARCH REPORT

International Application No  
PCT/NL 98/00732

<b>A. CLASSIFICATION OF SUBJECT MATTER</b> IPC 7 E21B43/10		
According to International Patent Classification (IPC) or to both national classification and IPC		
<b>B. FIELDS SEARCHED</b> Minimum documentation searched (classification system followed by classification symbols) IPC 7 E21B		
Documentation searched other than minimum documentation to the extent that such documents are included in the fields searched		
Electronic data base consulted during the international search (name of data base and, where practical, search terms used)		
<b>C. DOCUMENTS CONSIDERED TO BE RELEVANT</b>		
Category *	Citation of document, with indication, where appropriate, of the relevant passages	Relevant to claim No.
X	WO 93 06333 A (CONOCO INC) 1 April 1993 (1993-04-01) claims 1-3 figures 2,3,5-7 page 17, line 7-11 ---	10-12
X	US 5 165 476 A (JONES LLOYD G) 24 November 1992 (1992-11-24) column 4, line 27-30 column 4, line 47 - column 5, line 36 column 3, line 59-64 figures 1,2 ---	10, 17
X	WO 96 00821 A (QUALITY TUBING INC) 11 January 1996 (1996-01-11) page 2, line 14-24 page 12, line 34 - page 13, line 23 figure 2 ---	10
-/-		
<input checked="" type="checkbox"/> Further documents are listed in the continuation of box C. <input checked="" type="checkbox"/> Patent family members are listed in annex.		
* Special categories of cited documents : "A" document defining the general state of the art which is not considered to be of particular relevance "E" earlier document but published on or after the international filing date "L" document which may throw doubts on priority claim(s) or which is cited to establish the publication date of another citation or other special reason (as specified) "O" document relating to an oral disclosure, use, exhibition or other means "P" document published prior to the international filing date but later than the priority date claimed "T" later document published after the international filing date or priority date and not in conflict with the application but cited to understand the principle or theory underlying the invention "X" document of particular relevance; the claimed invention cannot be considered novel or cannot be considered to involve an inventive step when the document is taken alone "Y" document of particular relevance; the claimed invention cannot be considered to involve an inventive step when the document is combined with one or more other such documents, such combination being obvious to a person skilled in the art. "Z" document member of the same patent family		
Date of the actual completion of the international search  15 July 1999		Date of making of the international search report  30/07/1999
Name and mailing address of the ISA European Patent Office, P.B. 6018 Patentlaan 2 NL-2220 HV Rijswijk Tel. (+31-70) 940-2040, Tx. 31 651 epo nl, Fax. (+31-70) 240-3016		Authorized officer  Schouten, A

Form PCT/ISA210 (second sheet) (July 1992)

## INTERNATIONAL SEARCH REPORT

International Application No  
PCT/NL 98/00732

C.(Continuation) DOCUMENTS CONSIDERED TO BE RELEVANT		
Category *	Citation of document, with indication, where appropriate, of the relevant passages	Relevant to claim No.
X	US 5 355 956 A (RESTARICK HENRY L) 18 October 1994 (1994-10-18) abstract figures 1-5	10
A	US 5 366 012 A (LOHBECK WILHELMUS C M) 22 November 1994 (1994-11-22) cited in the application the whole document	1,10
A	TIM WALKER, MARK HOPMANN: "UNDERBALANCED COMPLETIONS" SPE 30648, 22 October 1995 (1995-10-22), pages 185-191, XP002109222 the whole document	1,10

1

Form PCT/ISA210 (continuation of second sheet) (July 1992)

**INTERNATIONAL SEARCH REPORT**

Information on patent family members

International Application No

PCT/NL 98/00732

Patent document cited in search report	Publication date	Patent family member(s)	Publication date
WO 9306333 A	01-04-1993	US 5228518 A	20-07-1993
		AU 2644392 A	27-04-1993
		CA 2117086 A	01-04-1993
		EP 0604526 A	06-07-1994
		NO 940920 A	23-03-1994
		US 5379838 A	10-01-1995
		US 5346016 A	13-09-1994
US 5165476 A	24-11-1992	NONE	
WO 9600821 A	11-01-1996	US 5526881 A	18-06-1996
		CA 2193864 A	11-01-1996
		GB 2304610 A, B	26-03-1997
		GB 2316345 A, B	25-02-1998
		GB 2316024 A, B	18-02-1998
		US 5622211 A	22-04-1997
US 5355956 A	18-10-1994	CA 2106922 A	29-03-1994
		GB 2271132 A	06-04-1994
		IT MI932061 A, B	28-03-1994
		NO 933338 A	29-03-1994
US 5366012 A	22-11-1994	AU 672008 B	19-09-1996
		AU 4324593 A	04-01-1994
		CA 2137565 A	23-12-1993
		DE 69305852 D	12-12-1996
		DE 69305852 T	22-05-1997
		DK 643795 T	14-04-1997
		WO 9325800 A	23-12-1993
		EP 0643795 A	22-03-1995
		JP 7507611 T	24-08-1995
		MD 960219 A	31-05-1997
		NO 944746 A	03-02-1995
		NZ 253125 A	27-02-1996